

# TracXP™

INDUSTRIAL GAS SOLUTIONS  
by Macurco

TracXP is the industrial products division of Macurco Gas Detection, who has been providing gas detection solutions for over 50 years. The TracXP line addresses special hazard applications including harsh industrial environments and hazardous locations with a comprehensive line of wired and wireless gas detection solutions.



## TXP-WABX

### Wireless Alarm Bar

The TXP-WABX Wireless Alarm Bar is a notification device suitable for Class 1, Division 2 applications. The TXP-WABX communicates directly with TXP-WTA transmitters as well as TXP-WCR and TXP-C16X control panels via 900 MHz radio signal. The onboard horn provides a nominal output of 112 dBA with field customizable volume control and has 64 different tones available. The amber and red Xenon strobes provide 360° visibility of low and high alarm status. A pole mount kit is included and is compatible with diameters up to 4". With a low profile and lightweight form factor of 33 pounds, this device can be easily transported and installed in remote or hard-to-reach areas.



TXP-WABX

### Key Features

- Suitable for Class 1, Division 2 applications
- Ingress protection: NEMA 4X
- Communicates via 900MHz radio  
(two to three miles line of sight)
- Input Voltage: 85 - 264VAC
- Includes 4" pipe mount kit (2)
- Horn Nominal Output: 112 dBA @ 1 M
- Selectable Horn Tone Options: 64
- Red and Amber Strobes:
  - Energy: 10 Joules (10Ws)
  - Flash rate: 1 Hz (60 fpm)

### Applications

- Oil & Gas
  - Upstream
  - Mid-stream
  - Downstream
- Refining & chemical production
- Water / wastewater treatment plants
- Food & beverage facilities
- Metal manufacturing
- Pulp & paper
- Power generation



TXP-WAR

## Specifications

### Controller Specifications

Dimensions	18.0" (L) x 18.7" (W) x 6.7" (H)
Shipping Weight	33.0 lbs. (15.0 k.)
Power Supply	85 - 264 VAC, 50 watt, 2.1 Amp
Horn	Maximum Output: 116 dBA @ 1 meter Nominal Output: 112 dBA @ 1 meter Selectable alarm stages/channels Choice of 64 alarm tone frequencies Adjustable volume control Temperature: -40°F to +158°F (-40 to +70°C) Approval: Class 1, Division 2
Strobes (2)	Strobe type: Xenon Amber and red lenses (standard) Mechanically secured against shock Energy: 10 Joules Flash rate: 1Hz (60 fpm) Peak candela: 1,000,000 calc. from energy (J) Temperature: -40°F to +122°F (-40 to +50°C) Approval: Class 1, Division 2
TXP-WAR	900 MHz or 2.4 GHz radio Non-volatile memory retains configuration values during loss of power Four alarm indicators Four alarm level relays and a horn relay Multiple password levels for security Display: 64 x 128 pixel backlit graphic LCD LED indicators for relay and comm. status Temperature: -40°F to +140°F (-40 to +60°C) Suitable for Class 1, Division 2 environments

## Wireless Alarm Bar

Part Number	Description
93-1132-AR00-03	TXP-WABX WIRELESS ALARM BAR

Represented By:

## TracXP Wireless Transmitters & Panels

Part Number	Description
83-1130-1000-10	TXP-WTA Aluminum Transmitter, Single Integral Sensor
83-1130-1100-10	TXP-WTA Aluminum Transmitter, Dual Integral Sensor
83-1330-2000-10	TXP-WTA Poly Transmitter, Single Integral Sensor
83-7002-0000-00	TXP-WTA Aluminum Remote Sensor Assembly (15 ft.)
83-7302-0000-00	TXP-WTA Poly Remote Sensor Assembly (15 ft.)
83-2340-0000-10	TXP-WCR Poly Control Panel, 32 Channel, 100-240 VAC
83-2240-0000-10	TXP-WCR SS Control Panel, 32 Channel, 100-240 VAC

## Standard Wireless Packages

Part Number	Description
83-KA00-0000-10	<b>TXP-SWP1 (Single)</b> (1) TXP-WCR poly, 50W, standard antenna, 10 ft. antenna extension, data logging / wired Modbus option (4) TXP-WTA aluminum, single integral sensor housing, magnetic mount kit, rainshield with calibration port <i>*Order Sensors Separately</i>
83-KB00-0000-10	<b>TXP-SWP2 (Dual)</b> (1) TXP-WCR poly, 50W, standard antenna, 10 ft. antenna extension, data logging / wired Modbus option (4) TXP-WTA aluminum, dual integral sensor housing, magnetic mount kit, rainshield with calibration port <i>*Order Sensors Separately</i>

\*For additional options please contact your TracXP representative

## Enclosure Dimensions

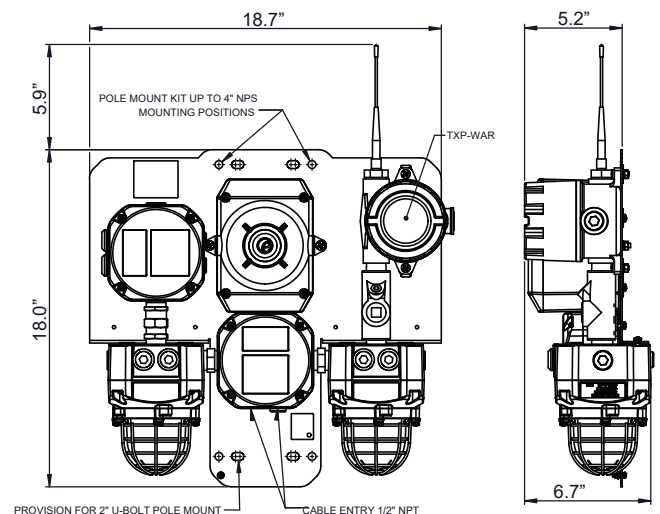

**Macurco Gas Detection**  
1504 W. 51st St,  
Sioux Falls, SD 57105

Since 1972 Macurco has been providing gas detection solutions for various applications. Macurco provides the highest quality gas detection solutions to customers worldwide.

Phone: 1-877-367-7891

Website: [www.macurco.com](http://www.macurco.com)

Email: [Macurco\\_info@dwyeromega.com](mailto:Macurco_info@dwyeromega.com)

