

Macurco™

BUILDING & HOME SOLUTIONS



Whether you are looking for gas detection for a security system, building automation or HVAC system, for personal safety or for monitoring specific gases in potentially hazardous environments, Macurco has a gas detector to meet your needs.

IAQ Series - Know Your Air

Indoor Air Quality Series

The Macurco IAQ product family is designed to help you “Know Your Air” in indoor applications. By precisely monitoring carbon dioxide (CO₂) levels, these devices support effective ventilation control, promote healthy indoor air quality, and contribute to energy savings.



IAQ Series



IAQ Series

Key Features

- Easy installation to single gang box
- Aesthetically pleasing- flush mount or surface options
- User selectable settings via two button interface
- 0.5A configurable (N.O. or N.C.) dry contact relay to engage ventilation
- Analog or digital outputs versions to send values to BMS
- Occupancy mode
- Adjustable setpoints
- End of life notification
- LCD display
- Last 30 day historical events:
 - Per day: Highest value, lowest value, average

Applications

- Homes
- Schools
- Conference rooms
- Theaters
- Airports
- Concert venues
- Convention halls
- Office buildings
- Universities
- Malls
- Retail

Specifications

Size	3.25"(H) x 5.25"(L) x 1.75"(W)
Shipping Weight	~ 1 lb. (~16 oz.)
Voltage/Current	12-24VAC or VDC
CO ₂ Sensor Type	NDIR Sensor
CO ₂ Range/Resolution	0-2,000PPM, 10PPM
Operating Temperature	32°F to 122°F (0°C to 50°C)
Ambient Humidity	10-99% RH non-condensing
Display	LCD 2x8 characters with backlight
Current Loop (Analog Only)	4-20mA output
Mounting	Flush to single gang box or surface mount
Relay	0.5A Control Relay User adjustable settings
Warranty	Two year limited warranty
Life Expectancy	10 years

*Please read manual for more specifications

Mounting



Flush mount



Surface mount

HOW TO ORDER

Use **Bold** characters from chart to configure product code

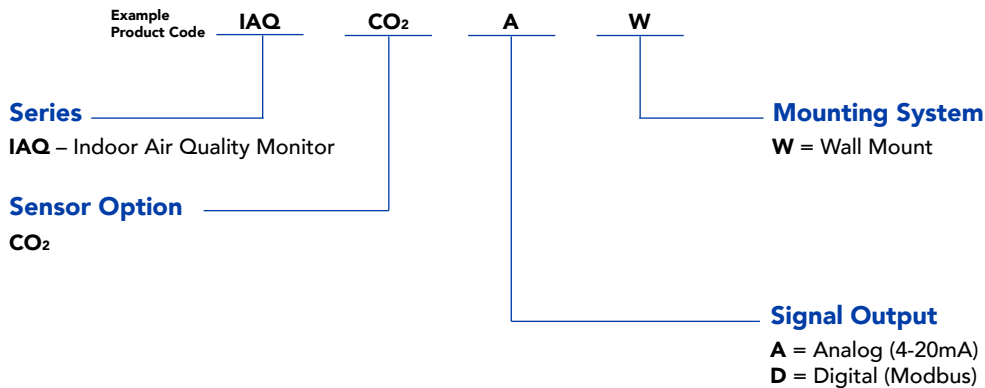

Since 1972 Macurco has been providing gas detection solutions for various applications. Macurco provides the highest quality gas detection solutions to customers worldwide.



Macurco Gas Detection

1504 W. 51st St,
Sioux Falls, SD 57105

Phone: 1-877-367-7891

Website: www.macurco.com

Email: Macurco_info@dwyeromega.com